



**Series N4000, N4500, N5000  
Installation Operation and  
Maintenance Manual**

**WATER FACTORY SYSTEMS®**

**N4000, N4500, N5000**

**Reverse Osmosis (RO) Drinking Water Appliance**



**Water Filter Systems**

CUNO Incorporated  
400 Research Parkway  
Meriden, CT 06450  
Tele: (203) 237-5541  
Fax: (203) 238-8701

# Introduction

This manual explains the installation and maintenance instructions for the water Factory Systems' N4000, N54500, N5000 Series Reverse Osmosis (RO) Drinking Water Appliances. Please read each section of this manual carefully. The specific model chosen should be appropriate for the local water conditions and the customer's needs. Check the Performance Data Sheet which specifies performance characteristics and the conditions of use.

The Water Factory Systems' undercounter RO drinking water appliances are designed to connect permanently to a home plumbing system. To ensure the installation conforms to your state and local plumbing codes, it is recommended that the installation be performed by a qualified specialist for RO drinking water appliances or a licensed plumber. Failure to install as instructed will VOID the warranty.

**Caution: The RO membrane cartridge is shipped with a preservative solution inside. Make sure to flush it thoroughly as directed before first use.**

## Table Of Contents

### Installation Instructions

- A. Determine the appliance location
- B. Prepare the area for installation
- C. Prepare the appliance for installation
- D. Install the feed water valve and tubing
- E. Prefill and sanitize the storage tank
- F. Install the drain connection
- G. Install the faucet
- H. Make the faucet mounting hole
- I. Mount the faucet
- J. Make initial tubing connections
- K. Install purification assembly and storage tank
- L. Make final tubing connections
- M. Install the icemaker hookup (optional)
- N. Start up the system
- O. Flush system of preservative and check operation
- P. Cleanup, paperwork, and customer orientation

### **Appendix for basement installations**

#### **Installation troubleshooting**

#### **Installation diagrams, (Figures 1-6)**

### Operation & Maintenance Instructions

- Important water quality assurance requirements
- Replacing the filter cartridges
- Replacing the RO membrane cartridge
- Sanitizing the RO appliance

# Installation Instructions

## A. Determine System Location (Figure. 1&2)

The appliance can be located under a sink or in a basement depending on space availability and the customer's preference. If a basement installation is selected, additional tubing, hardware and fittings may be needed and a hole will have to be made from inside the cabinet, through the floor, to the basement. Never install in an area of the home where temperature is freezing as damage to the system will result.

The exact placement of the various components of the appliance will vary from installation to installation. The installer, in conjunction with the customer, must decide on where to place the faucet, tank and purification assembly by balancing the homeowner's convenience with ease of installation and servicing.

Considerations for an icemaker or other remote hookup should be predetermined, including routing and any additional tools, fittings, and tubing that may be required.

## B. Prepare The Area For Installation

To save time it is often advised to call the customer and request they clear under the sink prior to arrival. Otherwise, remove supplies from under the sink and stack them neatly away from the working area. Arrange a light for the work area, if necessary.

If a basement installation is called for, determine where components will be located and how they will be mounted. Special mounting brackets and hardware may be necessary to secure the system to a wall or ceiling joints.

Inspect cold water supply line and drain to determine if any special fittings, in addition to what is included in the kit, are required.

**NOTE:** It is a good idea at this time to check the condition of the customer's undercounter plumbing for any existing or potential leaks. The customer should be advised of any problem so there is no misunderstanding of who is responsible.

## C. Prepare The Appliance For Installation

Open shipping carton and remove components. Check that all installation parts are present which includes the purification assembly, storage tank, faucet, installation hardware and tubing.

Check that the air supply in the empty tank is approximately 7 psi. Adjust if necessary.

If optional percent rejection monitor is selected, probes should be installed at this time. Follow instructions that come with the monitor.

The saddle tapping valve supplied is designed for use with 3/8" to 1/2" O.D. soft copper supply tubing (plain or chromed) and rigid metal pipe (see below). Do not use with flexible ribbed supply tubing which has too thin a wall thickness and requires special hardware. Optional feed valves can be specially ordered from the factory for this purpose. Also refer to figure 6 on use of the "Push In" plastic fittings.

### Soft Copper Tubing Installations:

- A)** Turn off cold water valve under the sink, or main valve for the house.
  - B)** Before installing saddle tapping valve, make sure piercing lance does not protrude beyond rubber gasket. See instructions on bag.
  - C)** Assemble both halves of saddle tapping valve on copper tubing.
  - D)** For 3/8" O.D tubing, use bracket with side projections to prevent distortion of tubing. Use "V" side of bracket for all larger size tubing. Tighten screws evenly and firmly - brackets should be parallel. Do not deform tubing. See diagram.
  - E)** To pierce soft copper tube, turn handle clockwise until it is firmly seated. The valve is closed in this position.
  - F)** Turn on main supply valve to pressurize cold water line. Check for leaks. With a wrench, tighten nut/seal around valve stem.
  - G)** Connect length of orange 1/4" tubing to the feed water valve, using brass compression nut, insert, and plastic sleeve. See diagram.
- NOTE:** For basement installations, a longer length of feed water tubing may have to be used.

**IMPORTANT: Some local plumbing codes may prohibit the use of saddle-type valve connections. Optional feed valve assemblies can be specially ordered from you supplier. See page 11 for further information.**

### Rigid Metal Pipe Installations:

- A)** Turn off cold water supply valve and drain the line to prevent spillage.

**B)** Drill 3/16" hole at the desired location. To prevent shock hazard, use a battery operated drill.

**C)** Turn valve handle clockwise to expose piercing lance beyond the rubber gasket no more than 3/16".

**D)** Assemble saddle valve on the supply pipe by screwing the two halves together. Use the "V" side of the bracket. Tighten screws evenly and firmly, keeping the two sides of the bracket parallel.

**E)** Turn saddle valve handle clockwise to close valve. With a wrench, tighten nut/seal around stem.

**F)** When you wish to open valve and supply cold water to the unit, turn valve handle counterclockwise.

**G)** Connect appropriate length of 1/4" tubing to the feed water valve, using brass compression nut, insert, and plastic sleeve. See diagram.

**NOTE:** For basement installations, a longer length of orange feed water tubing may have to be used.

## E. Prefill And Sanitize The Storage Tank

Prefilling the tank is always recommended so there is pressure to check for leaks and several gallons of water to flush carbon post filter. Tanks are furnished with a special disinfection capsule which sanitizes the tank when it is filled with water. An instruction tag will accompany the tank. It is important to use a sanitizer when prefilling the tank so the solution can sanitize the tubing, fittings, and faucet at the time of installation and startups.

**A)** Insert free end of orange feed water tubing into the "Push In" fitting on the storage tank.

**B)** Open feed water valve and tank and allow to fill (about 3 minutes).

**C)** Turn off feed water valve and tank valve and set tank aside (15 minutes minimum).

**NOTE:** If an alternative storage tank is used without a disinfection capsule, it should be sanitized with household bleach (5.25%). Use 1 ml bleach per gallon of tank capacity.

## F. Install The Drain Connection (fig.4)

**For Basement Installations See page 8**

**Undercounter Installations:**

**IMPORTANT: Before starting this procedure, inspect the condition of the drain piping, especially in older homes where the traps and tailpieces can be deceptively thin and frail. If in poor condition, it is wise to inform the customer that the condition should be remedied.**

**IMPORTANT: Some local plumbing codes may prohibit the use of saddle-type drain connections. See page 11 for further information.**

The drain saddle assembly is designed to fit around a standard 1-1/2" O.D. drain pipe. For smaller (lavatory type) or larger (ABS pipe) drains, consult the factory for special drain saddles.

The drain saddles should always be installed above (before) the trap and on the vertical or horizontal tailpiece. Never install the drain saddle close to the out-let of a garbage disposal or plugging of the RO drain line may occur.

**A)** Position threaded half of drain saddle at selected location and mark the spot through the opening.

**B)** Drill a 1/4" hole at the marked spot through one side of drain tailpiece.

**C)** Position both halves of drain saddle on drain pipe so threaded opening lines up with the hole in drain pipe.

**D)** Use bolts and nuts to clamp drain saddle onto drain pipe. Do not over tighten and make sure there is equal space between saddle halves on each side.

**E)** Wrap Teflon® tape on thread of drain saddle elbow and tighten into drain saddle. Orient elbow in the direction of RO faucet location.

## G. Install The Faucet (Fig.5)

Undercounter installations generally require that the faucet is installed with the air gap module. In basement installations, the air gap module can be eliminated only if one is provided elsewhere in the drain line.

**IMPORTANT: The Uniform Plumbing Code dictates that there must be an air gap between the RO line and the waste drain.**

**NOTE:** An optional non-air gap faucet, which requires a smaller (9/16") hole, is available from the factory to make basement installations easier.

A wide variety of RO faucet mounting situations can be encountered, the most common being stainless steel and ceramic on metal sinks. Consult the factory for other materials encountered.

The customer should be consulted before determining faucet location. The faucet should be positioned so that it empties into the sink and the spout swivels freely for convenience.

If the sink already has a hole provided that can accommodate the RO faucet, then no drilling is required and you can proceed to the section on mounting the faucet.

**NOTE:** With the customer's permission, sprayers can be disconnected to provide a suitable hole for the RO faucet. A pipe cap or plug will be required to seal the sprayer connection. A special kit which provides a sprayer for the end of the kitchen faucet and an assortment of caps and plugs are available.

## H. Make The Faucet Mounting Hole

**IMPORTANT: It is mandatory that safety glasses be worn during sink hole drilling operations to prevent eye injury.**

Before starting the hole making operation, always check below the sink so that nothing interferes with mounting the faucet such as reinforcing ribs, support brackets or cabinet construction.

**Stainless steel sink, faucet with or without air gap module:**

**Recommended tools:**

- Center punch
- Variable speed drill and high speed drill bits
- Greenlee chassis punch 7/8" hole size (alternate 9/16" size may be used for faucets without air gap module)

**Procedure:**

- A) Center punch a small indent at the desired faucet location.
- B) Slowly drill required pilot hole for the chassis punch.
- C) Set up the chassis punch per instructions and tighten nut to cut the desired hole size.
- D) Clean up sharp edges with a file if necessary.

**Porcelain/Enamel/Ceramic** on sheet metal or cast iron base; faucet with or without air gap module:

**Recommended Tools:**

- Variable speed drill
- Relton porcelain cutter tool set 7/8" size (alternate 9/16" porcelain bit may be used for faucets without air gap module)
- Plumber's putty

It is important to understand what is involved

in this procedure. First, the glassy layer of porcelain must be penetrated through to the base metal. Second, a center disc of porcelain must be removed while protecting the surrounding porcelain against chipping or fracturing. Third, the base metal must be drilled through to complete the hole.

**Procedure:**

- A) Mark the center for the 7/8" hole
- B) Form shallow putty dam around hole area and fill with enough water to lubricate carbide drill bit.
- C) Carefully drill pilot hole through porcelain/enamel and base metal using carbide type pilot drill.  
**IMPORTANT: Always operate drill with light pressure at slow speed (300-400 rpm)**
- D) Insert pilot tip of spring loaded porcelain cutter into pilot hole.
- E) Drill porcelain/enamel using spring-loaded porcelain cutter, making certain a complete ring has been cut through the porcelain/enamel to the metal base.
- F) Change to the metal cutter. With slow speed and light pressure, cut away the inner porcelain/enamel disc down to base metal. Make certain that the cutter does not touch outer rim of the cut porcelain/enamel. Continue with this bit to cut through metal until sink has been completely penetrated.

**IMPORTANT: When using a porcelain cutter it is critical to take precautions that it is always in a sharpened condition. Dull cutters are known to chip sinks.**

## I. Mount The Faucet (Fig. 5)

**For basement Installations Without Air Gap Module See Appendix**

**Undercounter Installation With Air Gap Module:**

- A) Familiarize yourself with all components shown in the air gap faucet diagram.
- B) Disassemble hardware from the threaded nipple, except for chrome base plate and rubber washer.  
**NOTE:** Rubber washer may be replaced with bead of plumber's putty for neater appearance.
- C) Connect length of standard green 1/4" tubing to smaller barb on air gap faucet. Push on firmly until it seats.
- D) Connect length of black 3/8" tubing to larger barb

on air gap faucet. Push on firmly until it seats.

**E)** Feed the air gap tubing and threaded nipple through sink/counter mounting hole and orient the faucet as discussed with the customer.

**F)** From below sink/counter assemble the white spacer (open end up, open side toward air gap), flat washer and hex nut on threaded nipple and tighten by hand.

**G)** Back off on hex nut just enough to slide slotted washer between white spacer and underside of sink/counter (with open side of slotted washer closest to air gap tubes).

**H)** After rechecking faucet orientation, tighten hex nut (9/16" wrench or deep socket) until faucet feels secure.

**I)** From above the sink make any minor orientation corrections by turning the faucet with a padded adjustable wrench.

**NOTE:** Flats on chrome faucet may be used for tightening with an adjustable wrench. Use care not to mar chrome finish.

## **J. Make Initial Tubing Connections (Fig. 1)**

**For Basement Installation See Appendix**

**Undercounter Installation:**

**A)** It is advantageous to make some of the tubing connections at this time since access to the components is much easier now that the undersink area is less cramped.

**B)** The orange 1/4" tubing should already have been connected to the feed valve with a 1/4" brass compression nut, insert and plastic sleeve.

**C)** Connect 1/4" Blue tubing out of faucet to 3/8" x 1/4" union to 3/8" Blue tubing.

**D)** Connect the length of blue 3/8" tubing to faucet fitting.

**E)** Route black 3/8" tubing from faucet air gap module to drain saddle so that it slopes continuously downward without loops or low spots. Cut to proper length and connect to drain elbow by pushing tubing through nut then hand tightening nut onto body.

**F)** Connect length of yellow 1/4" tubing to "Tank" connection on purification assembly.

## **K. Install The Purification Assembly And Storage Tank**

**For Basement Installation See Appendix**

**Undercounter Installation:**

The purification assembly is usually mounted

to the right or left sink cabinet sidewall, taking into consideration the space available and the tank location. Generally, the tank is placed in the rear of the sink cabinet while the purification assembly is positioned toward the front for better accessibility.

To mount purification assembly elevate it at least 2" off the cabinet floor, while keeping level, mark the location of the mounting holes on the cabinet sidewall. Make small pilot holes with an awl or drill and screw in the two mounting screws, leaving just enough protruding to allow bracket mounting slots to slide over them.

**NOTE:** If the cabinet sidewalls are not of solid construction, the purification assembly can be set on the cabinet floor and held against the sidewall with the mounting screws. However, the purification assembly will then need to be lifted from mounting screws in order to remove filter housings.

The tank may be oriented either vertically or horizontally. It is generally placed to the rear of the cabinet but can be set in the front center (between the sink basins) for ease access if space permits.

## **L. Make Final Tubing Connections (Fig. 1)**

**For Basement Installation See Appendix**

With all of the components in place, the final tubing connections can be made. When routing tubing between components, several guidelines should be observed.

- Tubing runs should generally follow the contour of the cabinets rather than interfere with the cabinet storage area.
- Strive for neatness and an orderly tubing "flow" using fasteners (e.g. insulated staples) to secure the tubing.
- Arrange the tubing so there are no sharp bends and leave some "play" in the tubing for ease of servicing, then cut tubing to the desired length.
- Try to keep the tubing from the purification assembly to the tank and faucet as short as practical for good flow.

### **Undersink Installation**

**A)** Connect orange 1/4" tubing from feed water valve to "Feed" connection on purification assembly.

**B)** Connect blue 3/8" tubing from faucet to the "Faucet" connection on purification assembly.

**C)** Connect yellow 1/4" tubing from purification assembly to storage tank.

**D)** Route special red "SFC" tube from purification assembly module (factory made connection) toward faucet. Do not cut this special SFC tube. Its length is important to maintain proper efficiency and performance.

**E)** Cut the standard green 1/4" tubing from faucet air gap and connect to 1/4" coupling fitting on the end of "SFC" tube.

### **M. Install Icemaker Hookup (optional)**

The RO drinking water appliance can be connected to any standard refrigerator icemaker or icemaker/water dispenser. It should never be connected to a commercial type bar icemaker.

Hooking up an icemaker involves connecting a tee with shut off valve into the blue 3/8" faucet tubing and routing tubing over to the refrigerator. Hooking up to existing copper tubing is generally not recommended unless it is less than 6 months old. If copper tubing must be used, then installation open in-line carbon filter at the refrigerator connection is recommended.

Before turning off the existing tap water supply to a refrigerator icemaker, always shut off the icemaker first (usually by lifting the lever arm above the bin to the uppermost position). The icemaker should only be turned on again after the RO system has been drained several times and the tank has a full supply of water.

**NOTE:** Contact the factory for the availability of special icemaker hook-up kit.

**IMPORTANT: Before any service is performed on the RO system, always turn off icemaker valve and the icemaker unit. Only turn on when system is operating and tank is full.**

### **N. Start Up The System**

**A)** Double-check that all connections are secure.

**B)** Turn on feed water valve and check for leaks. If any leaks are noted, turn off valve and correct before proceeding. **NOTE:** If a leak occurs at "Push In" plastic fitting refer to figure 6.

**C)** Turn on storage tank valve and open faucet until a steady stream of water flows. Close faucet, wait at least 5 minutes and carefully check for leaks. Correct as necessary.

**NOTE:** When the system is first turned on, water may intermittently "spurt" from the air gap module.

This is perfectly normal and is caused by air trapped in the system. This will usually disappear within a short time.

### **O. Flush System of Preservative and Check Operation**

**A)** Lift faucet handle and allow tank to drain completely of sanitizing solution. Do not use this water. When tank is empty, the faucet will steadily drip. This is the rate water is processed by the RO system.

**B)** With faucet handle in "up" position, measure the rate of the steady drip from spout. Use a graduated cylinder (in milliliters) and a watch with a second hand to calculate approximate production in gallons per day (milliliters per minute X 0.38 = gpd). Proceed to check reject flow rate by disconnecting tubing at drain connection and measure as per above. The ratio should be a minimum of 2.5 (reject) to 1 (product).

**C)** Close faucet and reinspect system for leaks. Instruct customer (or use special faucet tag supplied) to wait at least 4 hours and drain tank again. The water should be discarded as it may contain some preservative/disinfectant solution.

**D)** System should be ready to use as soon as the tank refills. If any objectionable taste is noticed after second tank draining, instruct customer to wait and drain tank the following day. Only at this time should an icemaker be turned on if one is connected to the system.

**NOTE:** If optional percent rejection monitor is used and yellow light indicates service is required, several tankfuls of water may have to be used to completely flush excess TDS from the new carbon postfilter before a green light will show.

### **P. Clean Up, Paperwork And Customer Orientation**

**A)** Clean up the work thoroughly. This is important in leaving a good final impression with the customer.

**B)** Affix any special decals or stickers. Fill out the warranty card. Be sure to record the house pressure and TDS for your service files.

**C)** Familiarize family members with the general operation of their new RO drinking water appliance. In particular, note the following:

- The faucet handle positions, down for momentary flow, and up for continuous flow. Also, note the moveable spout.
- The location of the feed valve and tank shut off valve as well as the procedure for turning them off.
- Review the many uses of the water (cooking, soups, juices, ice cubes, baby formulas, pets, plants, etc.).
- Review the recommended maintenance schedule as determined by local water conditions.

## Appendix For Installations

The following variations are generally required for basement installations:

### I. Install The Drain Connection (Fig. 2)

For basement installations, the drain saddle is generally not used. Instead, the RO reject line is routed so that it drains into a laundry sink, floor drain, or standpipe through an approved air gap.

### II. Mount The Faucet (Fig.5)

If you choose to use the air gap faucet included with the RO system, follow the faucet installation instructions given earlier in the manual. Do not hook up any air gap tubing to the faucet since an alternate air gap will be used elsewhere in the drain line.

If you choose to use the optional non-air gap faucet, follow the instructions below.

- A)** Familiarize yourself with all components shown in the diagram of the non-air gap faucet.
- B)** Assemble only the chrome base plate and rubber sealing washer onto the threaded nipple. (Plumber's putty may be used in place of sealing washer for neater appearance.)
- C)** Feed threaded nipple through sink/counter mounting hole (9/16" hole is adequate).
- D)** From below the sink/counter assemble plastic bottom washer, flat washer, star washer, and hex nut onto the threaded nipple. Hand tighten hex nut until faucet feels snug.

**E)** After rechecking faucet orientation, tighten hex nut

(9/16" wrench or deep socket) until faucet feels secure.

**NOTE:** Flats on chrome faucet may be used for tightening with an adjustable wrench. Use care not to mar chrome finish.

### III. Make Initial Tubing Connections (Fig. 2)

**A)** A proper length of orange 1/4" feed water tubing should already have been connected to feed water valve with a brass compression nut, insert and plastic sleeve.

**C)** Connect proper length of blue 3/8" tubing to faucet fitting (See "Push In" fitting instructions). Route tubing through the floor to the vicinity of the purification assembly location.

**D)** Route standard green 1/4" tubing from an appropriate drain connection (e.g. laundry sink, floor drain, stand pipe) to intended location of purification assembly. An air gap must be installed between outlet and drain connection.

### IV. Install The Purification Assembly And Storage Tank

The purification assembly is generally mounted to the basement wall (using wall anchors) or to wood ceiling supports. To mount the purification assembly, keep bracket level and mark the location of the mounting holes. Install wall anchors and/or mounting screws as required. Leave screw heads protruding to allow bracket mounting slots to slide over them.

The tank may be oriented either vertically or horizontally and can be placed on a shelf, on the floor, or suspended from the ceiling supports using sturdy brackets.

An effort should be made to minimize the distance between the tank and purification assembly to assure an adequate flow rate to the faucet.

### V. Make Final Tubing Connections (Fig. 2)

**A)** Connect 1/4" orange tubing from feedwater valve to "Feed" connection on purification assembly.

**B)** Connect 3/8" blue tubing from faucet to the "Faucet" connection on purification assembly.



**C)** Connect 1/4" yellow tubing from purification assembly to storage tank.

**D)** Route **special** red "SFC" tube from purification assembly module (factory made connection) to standard green 1/4" tubing from drain. Connect tubes with the 1/4" coupling fitting on the end of "SFC" tube.

## INSTALLATION TROUBLESHOOTING

**Problem:** Leak at feed saddle valve.

**Cause:** Not clamped tightly enough.

**Solution:** Tighten saddle clamp screws evenly and firmly keeping both halves of the bracket parallel. Be sure not to deform tubing.

**Problem:** Leak at drain saddle.

**Cause:** Not clamped tightly enough.

**Solution:** Tighten drain saddle screws evenly and firmly.

**Problem:** Leak at threaded connection.

**Cause:** Improperly taped or not tightened sufficiently.

**Solution:** Retape threaded portion with Teflon® tape and thread in firmly. Do not over tighten.

**Problem:** Leak at push-in connection.

**Cause:** Tubing defect or misassembly.

**Solution:** Remove tubing. Squarely cut off 1/4 inch using a sharp razor knife and reinsert (see figure 6). Be sure tubing is pushed in fully until it seats.

**Problem:** Leak at filter housing.

**Cause:** Defective or misaligned O-ring.

**Solution:** Shut off feed valve. Shut off tank. Open faucet until it stops dripping or for a minimum of 5 minutes. Unscrew filter housing

and check condition of the O-ring. If misaligned, reseal. If damaged, replace.

**Problem:** Faucet leaks from spout with handle in closed position.

**Cause:** Obstruction or defective valve seat in faucet mechanism.

**Solution:** Remove spout with a twisting/lift motion and slide faucet handle forward over spout hole to gain access to faucet valve. Unscrew the tee-bar and slotted

bushing to remove valve. Clean out obstruction or replace with new valve mechanism as necessary.

**Problem:** No steady drip from open faucet after tank is drained.

**Causes:** **A)** Feed water valve not open.  
**B)** Feed water saddle valve not installed properly.

**C)** Leak from any product water connection.

**D)** Icemaker valve left open before start-up procedure completed.

**E)** Air still trapped in system.

**Solution:** **A)** Open valve fully.

**B)** Check valve installation making sure needle has pierced tubing.

**C)** Correct leak as outlined above.

**D)** Turn off icemaker valve and wait until faucet drips.

**E)** Wait for air to be purged.

**Problem:** Water leaks from opening in air gap module.

**Causes:** **A)** Drain line blocked or drain not drilled through completely.

**B)** Air lock in air gap outlet.

**C)** Excessive RO reject flow.

**Solutions:** **A)** Check that drain line is clear of obstruction and remove drain saddle fitting to verify that the hole is drilled through completely.

**B)** Blow air into air gap outlet using short length of tubing.

**C)** Disconnect special SFC reject tubing from faucet air gap inlet tubing and check reject flow rate which should be less than 175 ml/min. If greater than 175 ml/min., replace special SFC reject tubing with new one of proper length.

**Problem:** Too little or no reject flow.

**Causes:** **A)** Special SFC reject tubing plugged or defective.

**B)** Feed water saddle valve not open.

**C)** Obstruction in faucet air gap module.

**Solutions:** **A)** Replace SFC reject tubing with one of proper length.

**B)** Open feed water saddle valve fully.

**C)** Remove air gap module and inspect

internal flow path. Replace air gap module if necessary.

**Problem:** Chlorine or other unpleasant taste/odor after initial tank filling.

**Cause:** Residual preservative/sanitizer still in water.

**Solution:** Drain and fill tank several times if necessary.

**Problem:** Noise in drain ("gurgling" or "dribbling" sound).

**Cause:** Reject water dripping into standing water in the drain trap.

**Solutions:** A) Make sure the 3/8" black drain tubing from faucet air gap module slope continuously downward to drain saddle without loops or low spots.

B) Angle drain piping so reject water runs down side of drain pipe.

C) Change location of drain saddle to horizontal drain pipe or alternate vertical drain pipe farther from Purification Assembly. Properly plug original hole. **Caution: Make sure drain saddle is always installed above (before) the the trap. (Fig.4)**

## General Undercounter Installation Schematic (Fig. 1)

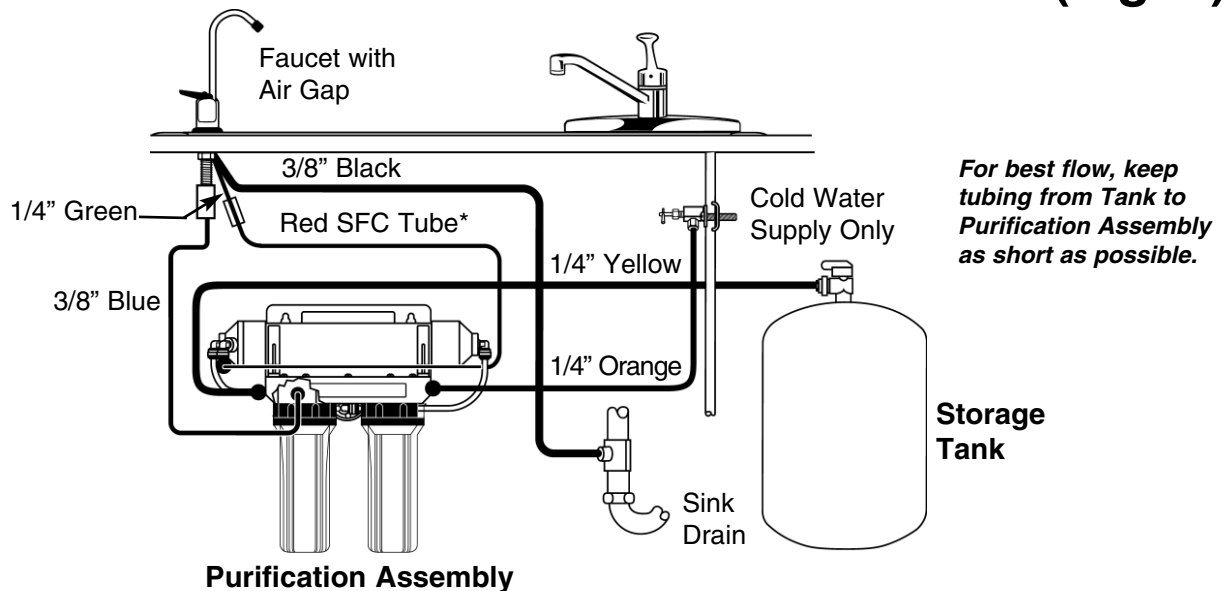

## General Basement Installation Schematic (Fig. 2)

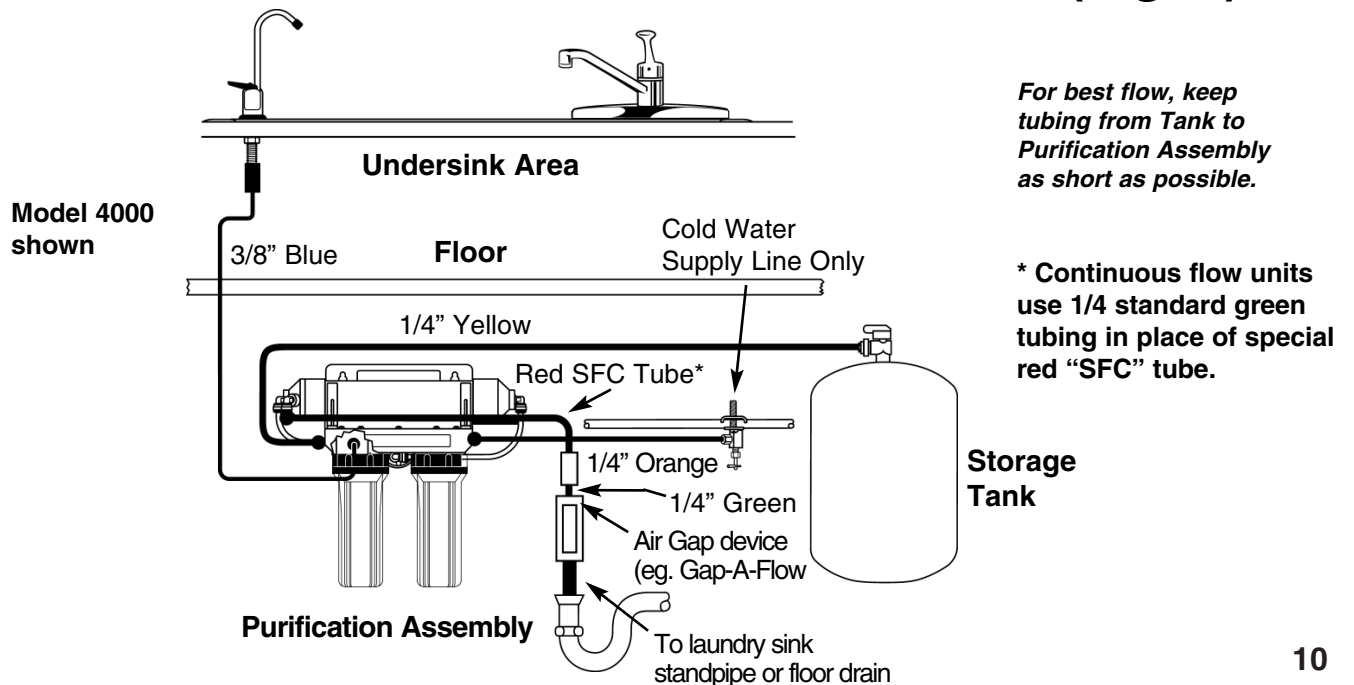

# Feed Water Valve Installation (Fig. 3)

(Important: See note on state requirements below.)

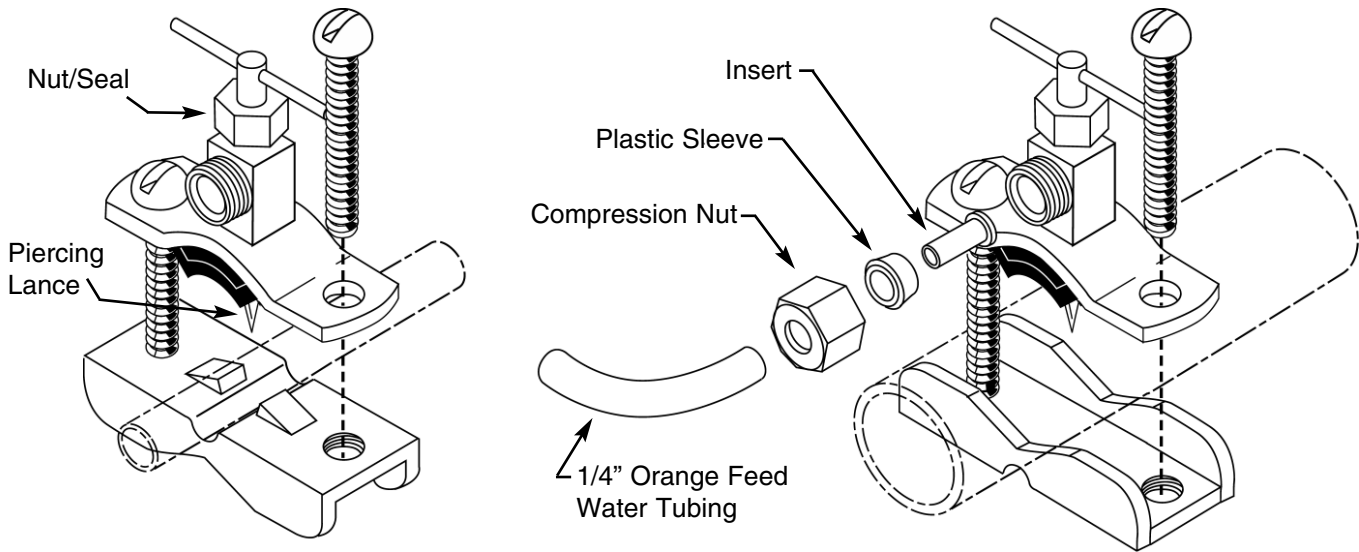

For 3/8" OD tubing use side of bracket with projections.

For 7/16" - 1/2" OD tubing or rigid pipe use "V" side of bracket.

# Drain Connection Installation (Fig. 4)

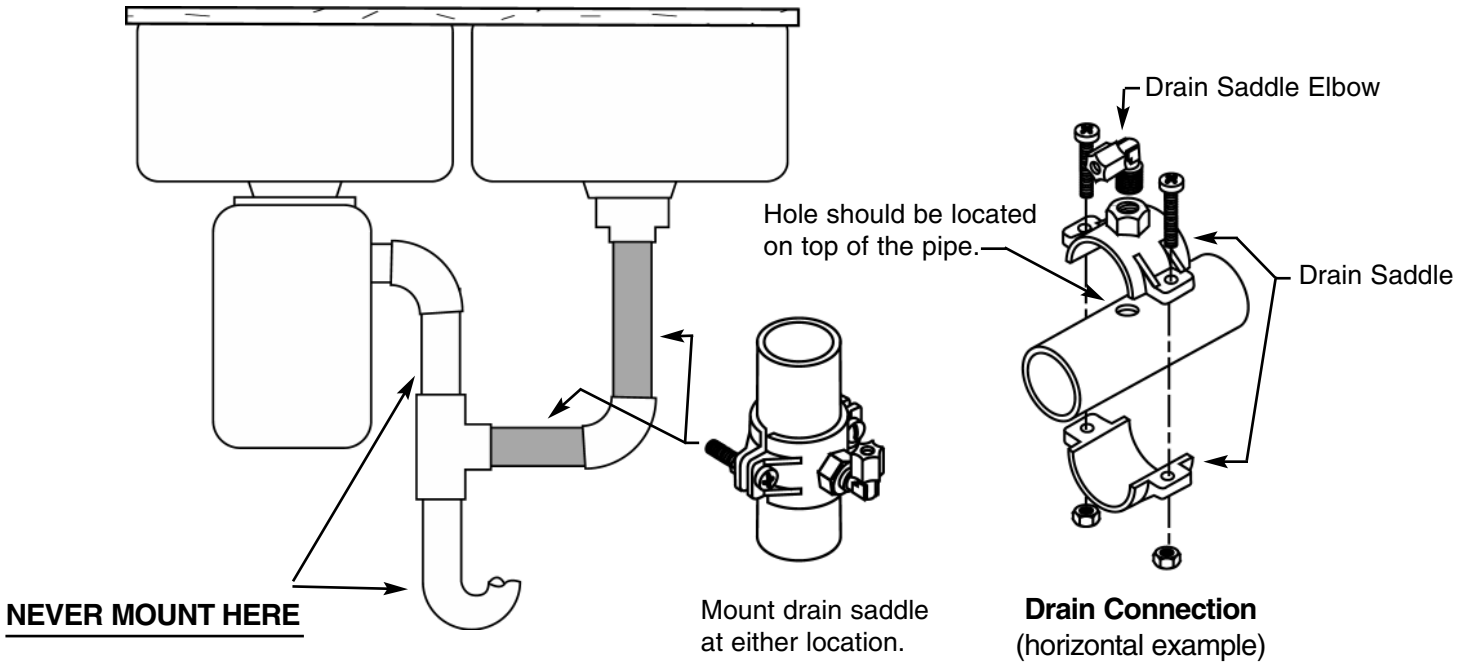

**NOTE:** Some state and local plumbing codes may prohibit the use of saddle-type valves and/or drain connections. The use of saddle-type valves are prohibited in: Alaskas, Delaware, Idaho, Kentucky, Massachussets, Michigan, Minnesota, New Hampshire, North Dakota, Oregon, and South Dakota. Check your local plumbing codes for any restrictions that apply. Massachusetts CMR 248 strictly prohibits the use of saddle type valves. The feed water connection must conform to applicable plumbing codes.

## Faucet Installation (Fig. 5)

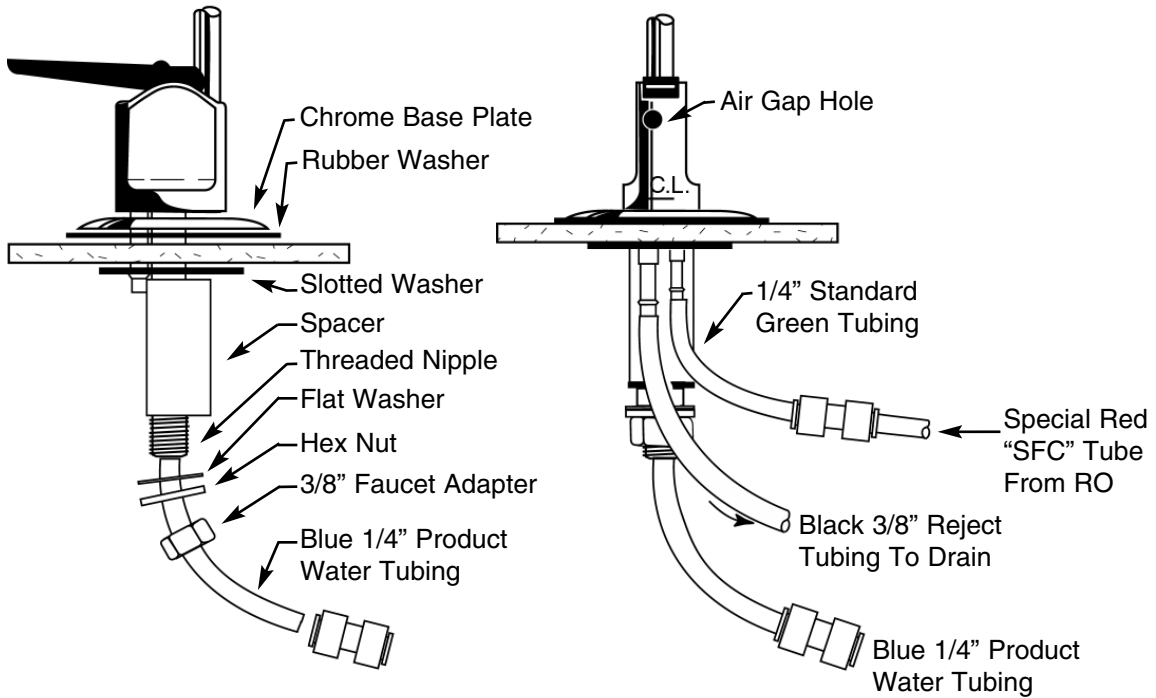

## How To Use 'Push-In' Connectors (Fig. 6)

This product is outfitted with user friendly "Push-In" connectors. Proper use of the connectors is shown in the diagrams.

It is most important that the tubing selected for use with these connectors be of high quality, exact size and roundness, and with no surface nicks or scratches. If it is necessary to cut the tubing, use a plastic tubing cutter or sharp razor knife. Make a clean square cut.

Should a leak occur at a "Push-In" connector, the cause is usually defective tubing.

- To fix:
- Relieve pressure.
  - Release tubing.
  - Cut off at least 1/4" from end.
  - Reattach tubing.
  - Confirm connection is leak free.

Push-In Tubing Connector

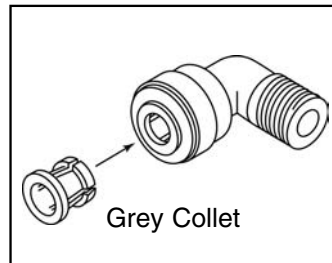

To Attach Tubing

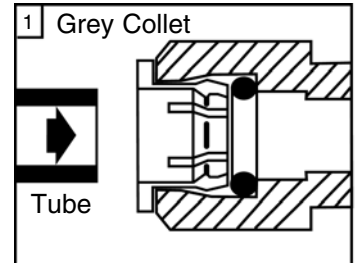

Tubing is secured in position.

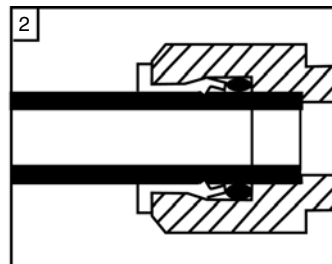

Tubing is secured in position.

To Release Tubing

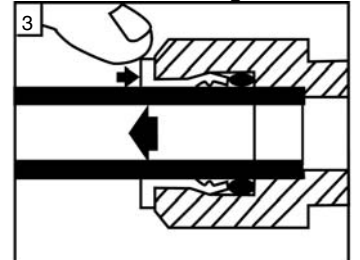

Push in grey collet to release tubing.

# Operation And Maintenance

## I. Important Water Quality Assurance Requirements

Reverse Osmosis drinking water appliances contain treatment components that are critical for effective reduction of Total Dissolved Solids as well as inorganic chemical contaminants. Water Factory Systems strongly recommends that the user test the water periodically (every six months minimum) to verify that the system is performing satisfactorily. Some models have a Percent Rejection (PR) Water Quality Monitor to provide the user with a means to test the water at any time. If a PR Monitor is not used, your dealer may offer a bi-annual water testing service. Routine maintenance is necessary in the form of prefilter, postfilter, and membrane replacement, based on the following guidelines:

- A)** Sediment Prefilter, Carbon Prefilter, or Sediment/Carbon Prefilter, optional Prolonged Contact Filter (PCF Models), and Carbon Postfilters - Change every six months to one year depending on feedwater quality.
  - B)** Membrane - Change as required based on:
    - Built in Percent Rejection Water Quality Monitor (PR Models only).
    - A bi-annual testing service may be offered from your dealer if a monitor is not used.
- NOTE:** Recommended maximum membrane service life is 36 months.

## II. Replacing Filter Cartridges

The life of prefilter cartridges generally depends on local water conditions (i.e., dirt, rust and/or chlorine levels) while the life of post filters is generally determined by the length of service.

### When To Replace Sediment Prefilter

- A)** Every six months to one year. Check cartridge after six months. If discoloration is observed on inside core or a layer of sediment is deposited on the outside surface, then the cartridge should be replaced. Otherwise, replace cartridge yearly.
- B)** As a rule, private wells require more frequent sediment prefilter changes while softened feed water usually requires only yearly replacement.
- C)** Recommended maximum sediment prefilter service life is one year.

### When To Replace Carbon Prefilter (4500 and 5000 Series Only)

The carbon prefilter removes free chlorine from the feedwater supply to protect the TFCM membrane from chlorine attack. To find out the chlorine level in a water supply, the water should be tested for free chlorine or call the public water supplier.

- A)** With free chlorine levels up to 1mg/L, the carbon prefilter should be changed every year.
- B)** With free chlorine levels exceeding 1 mg/L, the carbon prefilter should be changed every six months.

### When To Replace Carbon Postfilter

- A)** If the filter is being used to control tastes and odors, replace every year.
- B)** If the filter is being used to meet standards for chloramines, change every six months.
- C)** If the filter is being used to meet standards for a regulated organic chemical contaminant, then replacement should be based on a monitoring program established with a public health agency.

### How To Replace Prefilter And Postfilter Cartridges

Replacement of filter cartridges generally requires:

- New replacement cartridges
  - Water Factory filter wrench or equivalent
  - Replacement O-rings for filter housing(s)
  - Cleaning brush (optional)
  - Sanitizing supplies (See Section IV)
  - Cloth or sponge to clean up any spillage
  - Removal of the purification assembly from its location
- A)** Open faucet to drain tank and turn off feed water. Wait five minutes for purification assembly to depressurize.
  - B)** Using filter wrench, unscrew the filter bowl, counterclockwise viewed from the bottom.
  - C)** Discard water in bowl and the used filter cartridge. Set O-ring(s) aside.
  - D)** Scrub inside filter bowl with a brush using hot water and a mild detergent. Rinse thoroughly.
  - E)** Insert new filter replacement cartridge and follow instructions for sanitizing the purification assembly. Replace O-ring(s) if necessary. Note: O-rings should be lubricated before putting into service using a food grade silicone lubricant or glycerin.
  - F)** Attach filter bowls to proper purification assembly head(s).

- G)** Turn on feed water and carefully check for leaks.

### III. Replacing RO Membrane Module

The life of the RO membrane depends on local water chemistry and proper maintenance, e.g., regular filter changes. Under typical conditions, the RO membrane life ranges from 18 months to three years. Unlike filter cartridges, membrane life is not determined by the amount of water used because of its self-cleaning feature.

#### When To Replace The RO Membrane Module

- A)** As determined by a built-in percent rejection (PR) monitor. The monitor is factory preset so that a green light will be displayed when the water quality is good, and a red or yellow light indicates that replacement may be necessary. If a red or yellow light is displayed, the faucet should be opened and the storage tank drained. After it has refilled, check the system again. If a red or yellow light is still displayed, the RO membrane module should be replaced.
- B)** If a Percent Rejection Monitor is not used, your dealer or supplier may offer a bi-annual testing service. **NOTE:** Recommended maximum membrane service life is 36 months.

#### How To Replace The Membrane Module

Replacement of the RO membrane module generally requires:

- New replacement membrane module of the same type and specification
  - Sanitizing supplier (See Section IV)
  - Removal of the purification assembly from its location
- A)** Open faucet to drain tank completely and turn off feed water. Wait five minutes for purification assembly to completely depressurize.
- B)** Disconnect tubing from all three connections on membrane module.
- C)** Remove RO membrane module from clips and discard.
- D)** Position replacement module above clips and push into place. If necessary, rotate module so fittings are aligned with respective tubing.
- E)** Insert each tubing end into respective "Push-In" connector as far as it will go. (Figs. 6)
- F)** Follow sanitizing and start-up procedures for the storage tank and purification assembly outlined in

Section IV.

### IV. RO Appliance Sanitization

To assure the highest quality water from your Water Factor RO drinking water appliance, it is important to routinely sanitize both the storage tank and the purification assembly. **NOTE:** The following procedures are intended to be part of a routine maintenance program only and not designed to disinfect systems that have become highly contaminated from misuse.

#### When To Sanitize The Storage Tank

- A)** Upon start-up as described in Section N of the Installation Manual. **NOTE:** Standard Watery Factory RO storage tanks incorporate a special sanitizer which is activated when the storage tank is initially filled. See Section 6.
- B)** After any servicing or routine maintenance which involves the membrane, postfilter(s), tank, or faucet.

#### When To Sanitize The Purification Assembly:

- A)** After any servicing or routine maintenance which involves the prefilter(s) or membrane.
- B)** After any extended period of non-use (over 30 days).

#### How To Sanitize The Storage Tank

Sanitizing the storage tank generally requires:

- The Water Factory Tank Sanitizing Unit (P/N 50-011) or equivalent device such as an empty filter housing with fittings and tubing.
  - Common household bleach (5.25% - NON scented)
  - Measuring spoon or 0-10 ml graduated cylinder
- A)** Shut off feed water and open the RO faucet to empty out any water in the tank (it should feel "light").
- B)** Turn off RO faucet and valve at the top of tank. Disconnect tube to tank. Refer to use of special "Push-In" connectors (Fig. 6). Remove tank from its location and drain into sink by turning upside down and opening valve. Make sure outlet fitting is pointing away from your face and into the sink.
- C)** Make sure feedwater is off completely and disconnect feed tubing from purification assembly. Connect end of feedwater line to sanitizing device and tank as show in diagram.
- D)** Fill the sanitizer device with the following recommended dosage of common household bleach:

Standard 2.5 gallon tank - 1/2 teaspoon (3 ml)  
Alternate size tanks -1/2 teaspoon (3 ml) per 2.5 gallons of tank capacity.

- E)** Turn on the feed water valve to force water and sanitizer into the tank. Allow about three minutes of fill time for a standard 2.5 gallon tank. (It should feel heavy.)
- F)** The sanitizer should remain in the tank a minimum of 15 minutes. Turn off feed valve and tank valve. Disconnect the sanitizing device, reinstall the storage tank, and reconnect feed tubing.
- G)** Turn on feed valve to pressurize system. Turn on tank valve and open faucet to drain tank of sanitizing solution. When tank is empty, the faucet should steadily drip.
- H)** Close faucet and allow tank to fill for at least six hours. Drain tank again and discard water. The appliance should be ready to use as soon as the tank refills. If any objectionable taste is noticed, drain tank again and allow to refill.

### **How To Sanitize The Purification Assembly**

Sanitizing the purification assembly generally requires:

- New prefilter cartridge(s) and filter housing O-ring(s)
  - Water Factory filter wrench or equivalent
  - Common household bleach (5.25% - NON scented)
  - Measuring spoon or 0-10 ml graduated cylinder
  - Removal of the purification assembly from its location
  - Cloth or sponge to wipe up any spillage
- A)** Shut off feed water and open RO faucet to empty tank
  - B)** Follow instructions on changing prefilter
  - C)** Before attaching filter bowl(s) with new cartridge(s), pour one teaspoon (5 ml) of household bleach into the center of the filter cartridge(s).

**NOTE:** For 4500 and 5000 Series appliances, it is important that the bleach be poured directly down the center of the carbon prefilter cartridge to fill the small receptacle at the bottom of the bowl. When attaching the bowl, always keep upright to prevent spilling the bleach.

- A)** Allow system to run for at least six hours. Drain tank and discard water. The appliance should be ready to use as soon as the tank refills. If any objectionable taste is noticed, drain tank again and allow to refill.