

# R.O. DRINKING WATER SYSTEM MODEL T.F.C.-300

## INSTALLATION, OPERATION & SERVICE MANUAL

### **IMPORTANT NOTICES:**

This reverse osmosis system contains replaceable treatment components critical for effective performance. It is the user's responsibility to, and the manufacturer strongly recommends that the user, periodically test the product water to verify the system is performing satisfactorily.

**DO NOT USE WITH WATER THAT IS MICROBIOLOGICALLY UNSAFE OR OF UNKNOWN QUALITY, WITHOUT ADEQUATE DISINFECTION BEFORE OR AFTER THE SYSTEM.**

# TABLE OF CONTENTS

	Page
SECTION I. INTRODUCTION .....	3
SECTION II. SPECIFICATIONS .....	5
SECTION III. INSTALLATION STEPS .....	6
A. Faucet Installation .....	6
B. Feed Water Saddle Valve Installation .....	7
C. Drain Clamp Installation.....	7
D. R.O. Manifold Assembly Installation.....	8
E. Position the Drinking Water Holding Tank and Make the Final Hose Connections.....	9
F. Start Up .....	9
SECTION IV. OPERATION AND MAINTENANCE .....	10
A. Normal Operation .....	10
B. Changing Filters.....	10
SECTION V. TROUBLE SHOOTING GUIDE .....	12
EXPLODED VIEW AND PARTS LIST.....	14

**SECTION I. INTRODUCTION**

Your new Reverse Osmosis (R.O.) Drinking Water System uses a combination of filtration technologies to reduce unwanted contaminants in a water supply. The following steps combine to give you the best in clear sparkling drinking water:

**MECHANICAL FILTRATION/ACTIVATED CARBON**—The sediment prefilter will remove the larger particles such as silt, rust and scale. Its 5 micron (equal to 0.0002 inch) nominal rating helps to give maximum life to the R.O. Membrane. Activated carbon particles contain a vast network of pores. The tremendous surface area of these pores (typically 800–1200 square meters per gram of carbon) gives the carbon very good adsorptive sites for chlorine as well as other substances that contribute to taste and odors.

**REVERSE OSMOSIS MEMBRANE**—The R.O. Membrane is the heart of the filtration system. It is designed to reduce the dissolved mineral content of the water. Minerals picked up in the environment by the water are measured as Total Dissolved Solids (TDS). In the Reverse Osmosis process, dissolved minerals are separated from the incoming water (Feed Water) to produce the

product water (the Permeate). The excess minerals are rinsed to drain (the Reject Water).

The membrane is specially constructed, fully aromatic polyamide film and is classified as a Thin Film Composite (T.F.C.).

The spiral wound construction of the R.O. Membrane provides maximum surface area for water production and is less susceptible to fouling by particulate matter, turbidity and colloidal materials.

**ACTIVATED CARBON POST FILTER**—The product water from the Holding Tank passes through the Activated Carbon Post Filter on the way to the Dispensing Faucet. The Activated Carbon Post Filter reduces tastes and odors that may pass through the system. It adds a final “polish” to the water.

**AUTOMATIC SHUT-OFF VALVE**—The ASO Valve senses when the Holding Tank is full and closes the feed water supply to prevent excess reject water from going to drain when the unit is not producing water.

**TYPICAL T.F.C.—300 UNDER SINK INSTALLATION DIAGRAM**

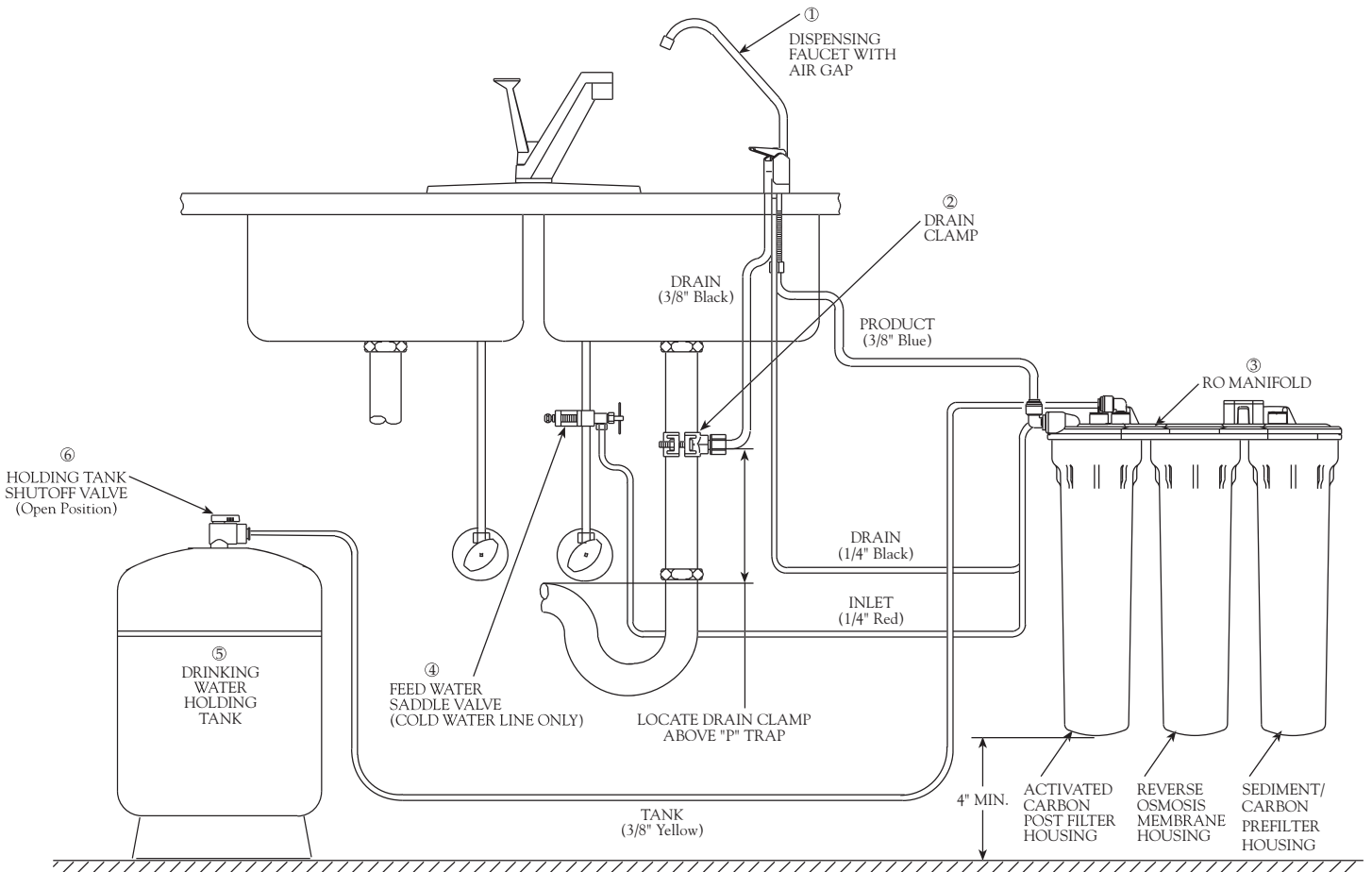

**Figure 1**

OPTIONAL T.F.C.-300 BASEMENT INSTALLATION DIAGRAM

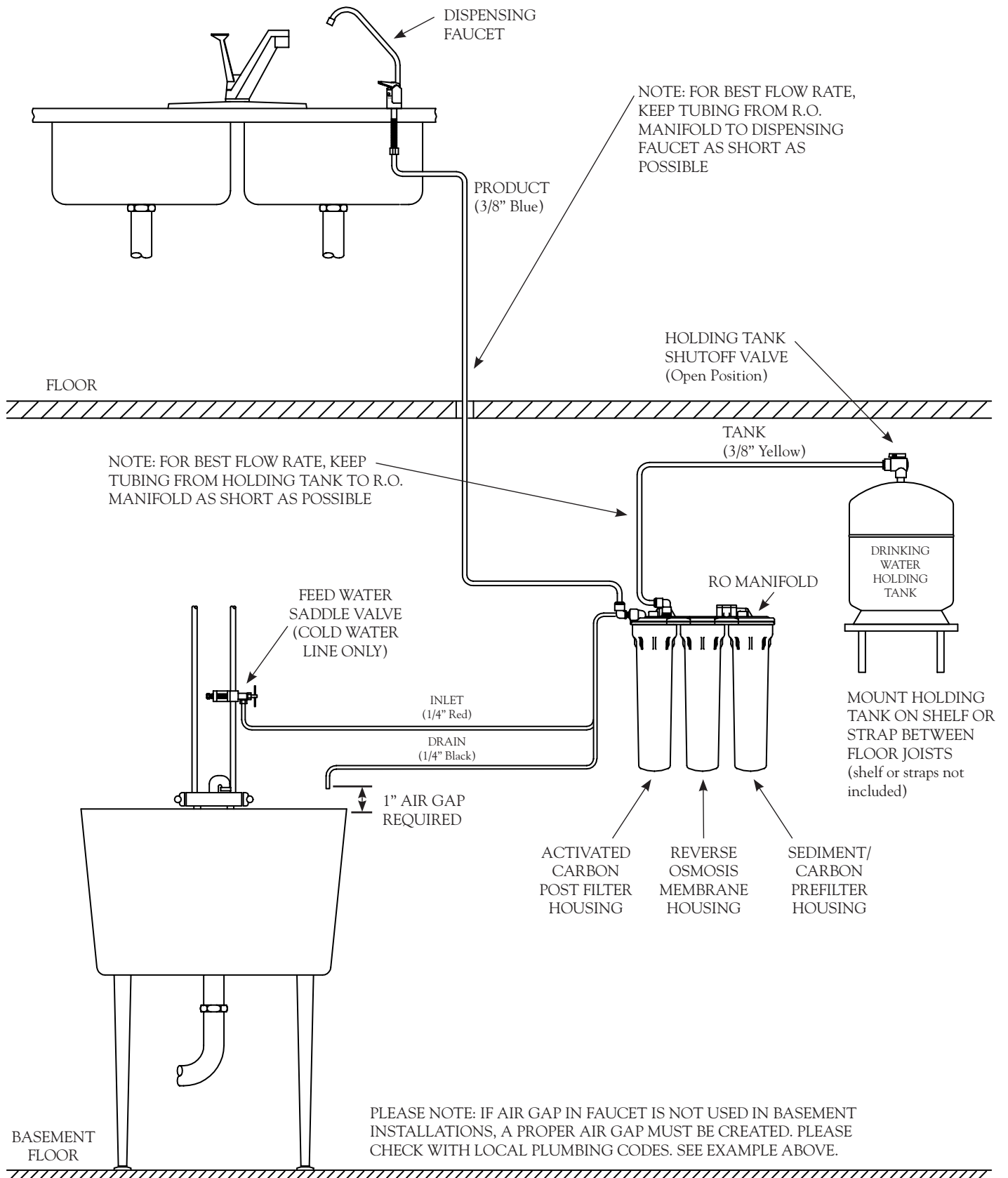

**SECTION II. SPECIFICATIONS**

**TABLE A – QUALIFIED SYSTEM PERFORMANCE**

Because the performance of an R.O. Membrane is highly dependent upon pressure, temperature, pH and TDS, the following should be used for comparison purposes only.

	<b>U.S.</b>	<b>Metric</b>
Membrane Production <sup>1</sup>	40-60 gpd	151-227 lpd
Membrane TDS Reduction <sup>1</sup>	93% minimum	93% minimum
Drain (reject water) Flow	3–5 x product flow	3–5 x product flow
Empty Storage Tank Precharge	5–7 psig air	35–48 kPa air

<sup>1</sup> Industry standards measure R.O. Membranes performance with no backpressure on the product water, at 65 psig (448kPa) and 77°F (25°C). Further conditions on the above are 600 ppm TDS. Production rate and TDS reduction figures are for a new Membrane that has been rinsed for 24 hours. The production rate of a new Membrane can decrease by 10% per year or more, depending upon the scaling and fouling tendencies of the Feed Water.

**TABLE B – RECOMMENDED OPERATING LIMITS FOR FEED WATER**

<b>Specifications</b>	<b>T.F.C. Membrane</b>
Water Pressure	40–100 psig (280–690 kPa)
TDS	2000 ppm (also mg/l) max.
Temperature	40–100°F (4–38°C)
pH	4–11 (optimum rejection at pH 7.0 - 7.5)
Hardness	Less than 10 gpg (170 mg/l) or soften
Iron	Less than 0.1 ppm (also mg/l)
Manganese	Less than 0.05 ppm (also mg/l)
Hydrogen Sulfide	None
Chlorine	See note
Bacteria	Must be potable**

**NOTE:** Chlorine will damage a T.F.C. Membrane. The Sediment/Carbon Prefilter will remove chlorine from the incoming water. Change filter every 6 months, more often if the water contains more than 1 ppm chlorine.

**\*\*DO NOT USE WITH WATER THAT IS MICROBIOLOGICALLY UNSAFE OR OF UNKNOWN QUALITY, WITHOUT ADEQUATE DISINFECTION BEFORE OR AFTER THE SYSTEM.**

### SECTION III. INSTALLATION STEPS

All plumbing should be done in accordance with state and local plumbing codes.

**NOTE:** Some codes may require installation by a licensed plumber; check with the local plumbing authority prior to installation.

In restricted under-sink areas, it may be easier to install the faucet first. Allow adequate tubing lengths for any final component position.

**A. Faucet Installation**—The faucet contains an anti-siphon air gap. While the system is producing water, the drain water flows from the R.O., through the air gap and then to the household drain. The purpose of the air gap is to prevent water in the drain from backing up into the R.O. Drinking Water System.

The easiest installation is to use an existing spray attachment hole. If the spray faucet hole is not available, then the sink top must be drilled.

1. Mark the location of the center of the faucet base.
- 2a. Drilling a stainless steel sink:
  - Center punch the hole to provide a starting point for the drill.
  - Start with a smaller drill as a pilot, and then drill a 1/2" diameter hole to accept the bolt of a 1 1/4" Greenlee Hole Punch (1 1/4" chassis punch).
  - Clean away any chips.
  - Install the punch and tighten the nut to cut the hole.
  - Deburr any sharp edges.

#### 2b. Drilling a porcelain sink:

It is best to use a special 1 1/4" diameter cutter designed for porcelain. A carbide tipped masonry bit is a second choice.

- Place a piece of tape over the area to be drilled to help prevent chipping.
- Drill a pilot hole for the porcelain cutter. Use the pilot drill supplied with the kit or a carbide tipped drill.
- When drilling the 1 1/4" hole, drill slowly and carefully; the porcelain chips easily.
- After drilling, clean the area well. Iron filings, if left in place, can cause rust stains.

#### 2c. Drilling a counter top:

**NOTE:** The counter top must be less than 1 1/4" thick. Treat ceramic tile as porcelain until the

tile is penetrated, then use the carbide tipped metal cutter.

Formica counter tops may be drilled with a good 1 1/4" wood bit; drilling a 3/32" pilot hole will help keep the bit going straight.

3. Assemble and attach the Faucet (Refer to Fig. 2, below.)

### LONG REACH AIR GAP FAUCET

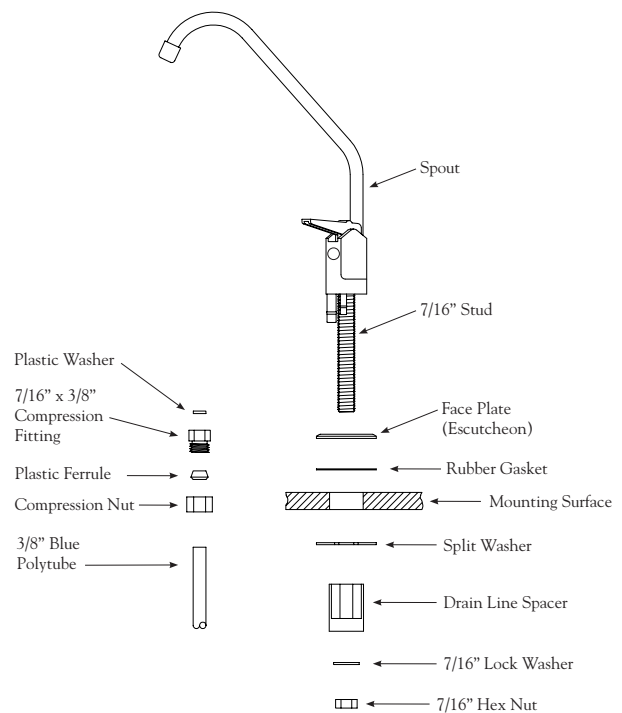

Figure 2

- Assemble the Body and Spout by removing the plastic shipping plug from the Body and then firmly pressing in the Spout.
- In the following order, place the Face Plate (Escutcheon) and Rubber Gasket on the 7/16" stud.
- From the top of the counter place the stud through the mounting hole.
- From the bottom of the counter top, in the following order, assemble the Split Washer, the Drain Line Spacer (with open end upwards), the 7/16" Washer and the 7/16" Hex Nut.
- To the end of the 7/16" stud put on the Plastic Washer, Compression Fitting, Plastic Ferrule and Compression Nut. Once snug by hand take a pair of pliers and tighten the fitting. Don't over tighten.

- Rotate the Spout and Body into position. Align the Split Washer and the Spacer to allow access to the Hose Barbs, and tighten the Hex Nut while holding the faucet in alignment with a padded Crescent wrench. Do not over tighten.

## B. Feed Water Saddle Valve Installation

Decide on location. Do NOT connect to a hot water feed line. If you are not sure of the supply, run the hot water and feel the supply piping. Water over 100°F may cause permanent damage to the R.O. Membrane. (Refer to Fig. 3 below.)

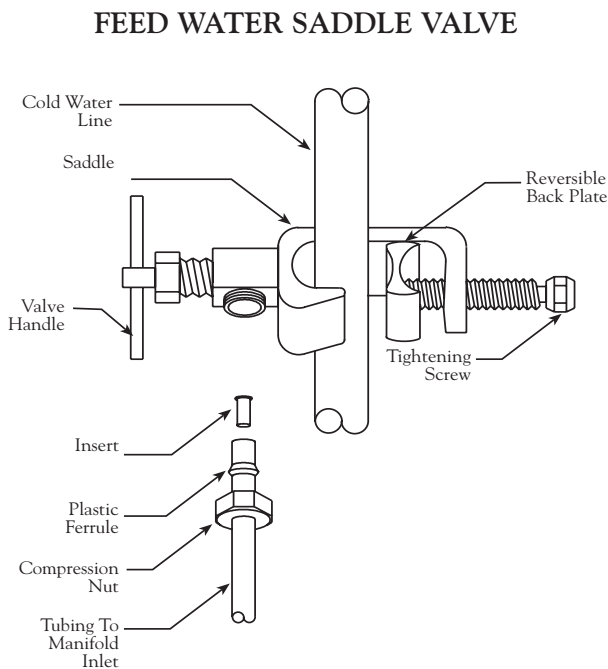

Figure 3

1. Shut off the water supply and drain the line.
  - 2a. To install on (soft) Copper Tubing supply line:
    - Turn the Handle of the Feed Water Saddle Valve counter clockwise (outward) until the lance does not protrude from the gasket. It may have to be pushed in.
    - Assemble the Feed Water Saddle Valve on the tubing.
      - for 3/8" OD tubing use the back plate side with the small groove to prevent distortion of the tubing.
      - for larger tubing (up to 5/8" OD) use the large groove of the back plate.
    - Assemble and tighten the brass screw.
    - To pierce the tubing, turn the Valve Handle

fully clockwise (inward). A small amount of water may escape from the outlet until it is fully pierced.

When you feel the Valve Handle firmly seated in the clockwise direction, the copper tube is pierced and the valve is closed.

- 2b. To install on (hard) Steel or Brass Tubing supply line.
  - The supply line should now be drained. Use a battery powered or properly grounded drill to avoid shock hazard.
  - Drill a 3/16" hole in the supply line; (do not drill through the opposite wall).
  - Turn the handle to expose the lance no more than 3/16" beyond the rubber gasket.
  - Place the body of the valve over the hole so that the lance fits into the hole.
  - Assemble and tighten the brass screw.
  - Turn the Valve Handle clockwise (inward) until firmly seated. The valve is closed.
3. With the Feed Water Saddle Valve closed, open the sink faucet and the water supply and allow the water to run for a few minutes to flush any debris caused by the installation.
  - Close the faucet and check the Feed Water Saddle Valve for leaks.

## C. Drain Clamp Installation

The following are instructions for discharging into the sink drain pipe. (Refer to Fig. 1, page 3.)

1. Position the Drain Clamp on the sink drain pipe above the drain trap. Allow room for drilling. Tighten securely.
2. Use a battery powered or properly grounded drill. Using the Clamp port as a drill guide, drill a 7/32" hole through the wall of the drain pipe. Do NOT penetrate the opposite side of the pipe.
3. Locate the 3/8" Black Drain Tubing which is shipped loose in the box.

**NOTE:** When cutting the polytubing make clean, square cuts, failing to do so could result in poor connections and possible leaks.

**NOTE:** The lowest point of the line should be the point of connection to the Drain Clamp. There should be no sag in the line as this may cause excessive noise as the reject water is flowing to drain.

## 3/8" DRAIN CLAMP ASSEMBLY

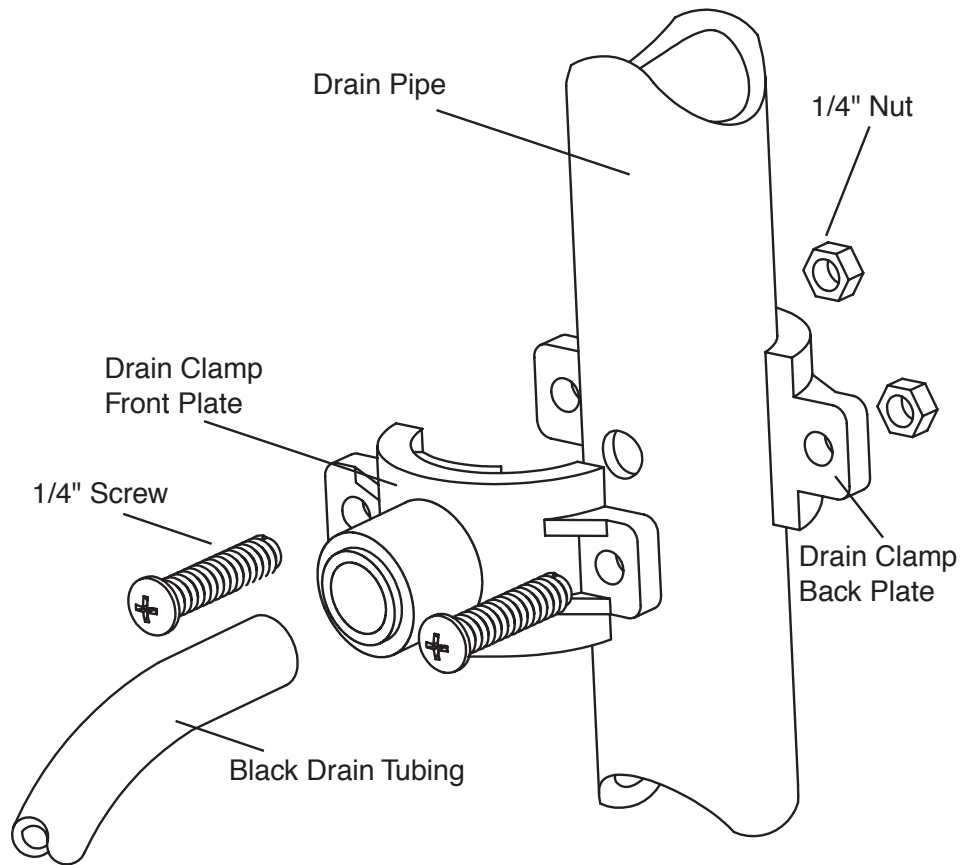

Figure 4

Firmly press one end of the tubing over the 3/8" drain outlet hose barb on the Air Gap Faucet. Allow the tubing to relax, then press firmly again to insure proper seating. No connectors are required when attaching hose to Hose Barbs. Route the tubing to the Drain Clamp and trim to length.

- Refer to Fig. 4, above. Insert the tubing into the Drain Clamp. Make sure the tubing is pressed all the way.

### D. R.O. Manifold Assembly Installation

Various installation sites will require different types of mounting fasteners; be sure the fastener selected will provide a firm, solid mounting. A support panel may be necessary on thin cabinet walls or to span between wall studs on particle board or drywall.

Do not drill through exterior cabinet walls or leave sharp wood screw points exposed in readily accessible cabinet interiors.

The close proximity of a dishwasher or a trash compactor may require special fabrication of a mounting plate.

1. The mounting bracket will accept either #10 or #12 (5 mm) mounting screws spaced on 6" (15 cm) centers. Allow at least 4" (10 cm) of clearance beneath the filter housings to accommodate filter changes. Mark the two locations (the bracket can be used as a template). Install the screws and tighten them until the heads are about 5/8" from the wall.
2. Locate the 1/4" Red Feed Water Tubing. Remove the red plug from the fitting labelled "In" on the manifold and insert the tubing. Reference the special supplement sheet in the carton for proper connection of all tubing and removal of plugs. Run the tubing along its course to the Feed Water Saddle Valve, trim to length. (Refer to Fig. 1, page 3.)  
Refer to Fig. 3, page 7. To the end of the red polytube install the Compression Nut, the Plastic Ferrule, and the Insert. Connect to the Feed Water Saddle Valve.
3. Locate the 1/4" Black Drain Tubing. Remove



the black plug from the fitting labelled "Drain" on the manifold and insert the tubing. The end of the Black Drain Tubing that should be inserted into the "Drain" port will have a green drain restrictor in it. Run the tubing along its course to the ¼" Hose Barb on the Dispensing Faucet, trim to length and connect by firmly pressing over the barb. Allow the tubing to relax, then press firmly again to insure proper seating.

4. Locate the 3/8" Blue Product Water Tubing. Remove the blue plug from the the elbow connected to the fitting labelled "Out" on the manifold and insert the tubing. Run the tubing along its course to the Dispensing Faucet and trim to length. See Fig. 2, page 6 for proper installation.
5. Locate the 3/8" Yellow Tubing. Remove the yellow plug from the fitting on top of the manifold labelled "Tank" and insert the tubing. (Refer to Fig. 1, page 3.)
6. Hang the Manifold Assembly on the mounting screws and tighten. **DO NOT OVERTIGHTEN.**

#### **E. Position the Drinking Water Holding Tank and Make the Final Hose Connections.**

1. Check the tank precharge pressure. Make sure it is between 5 to 7 psig. If not, use a bicycle hand pump or other pump to bring the pressure up to the 5 to 7 psig range.
2. Pull the cap/plug off the top of the tank where the Tank Shut-Off should go. (Refer to Fig. 1, page 3.)
3. Wrap Teflon tape around the ¼" male outlet thread. Wrap in the direction of the threads (clockwise, when looking down on the Holding Tank). The tape will act as a thread sealant. Screw on the Holding Tank Shut-Off Valve.
4. Locate the 3/8" Yellow Tubing which is attached to the elbow on top of the manifold and run the tubing along its course to the tank and trim to length. Insert the tubing into the Holding Tank Shut-Off Valve fitting. Make sure the tubing is pressed in all the way past the O-ring. The fitting will grab the tubing and seal it in place.

#### **F. Start Up**

At time of start up and each time the filters are changed the system should be sanitized (also see Operation and Maintenance Sec. IV, B.1-4, page 10).

1. Sanitizing the system. Use a drip pan to aid clean-up.

**NOTE:** The system should be sanitized BEFORE installing the Sediment/Carbon Prefilter, the Activated Carbon Post Filter or the R.O. Membrane.

- Use a good quality unscented 5¼% liquid chlorine household bleach.
- Open the Dispensing Faucet by lifting the black handle and open the Holding Tank Shut-Off Valve (the handle should be parallel with the valve body).
- Remove the plug on the underside of the manifold labelled "SEDIMENT/CARBON". Pour one capful of bleach (this is approximately 2 tsp. or 10 ml) into one of the white Housings. Insert Housing O-ring into the Housing groove, (press firmly in place). Engage and firmly tighten the Housing hand tight only.
- Remove the plugs labelled "MEMBRANE" and "ACTIVATED CARBON" from the underside of the manifold. To each of the remaining white Housings, add one capful of bleach. Insert a Housing O-ring, engage and firmly tighten the Housings hand tight only.
- Slowly open the Feed Water Saddle Valve (turning counter clockwise).
- As soon as the water begins to come out of the Dispensing Faucet, close the Faucet.
- Let stand for 15 minutes.

**NOTE:** During this time, check the system carefully for leaks.

- At the end of 15 minutes, CLOSE the Feed Water Saddle Valve and open the Dispensing Faucet.
  - Allow the Holding Tank to completely drain, then remove the Sediment/Carbon Filter Housing (the farthest of the three from the In-Out ports), empty, and install the Sediment/Carbon Prefilter. Firmly tighten the Housing hand tight only.
  - Remove the Activated Carbon Filter Housing (the closest of the three to the In-Out Ports), empty, and install the Activated Carbon Post Filter. Firmly tighten the Housing hand tight only.
2. Installing the R.O. Membrane:
    - Remove the R.O. Membrane Housing, (the middle one), and empty.

- Insert the Membrane up into the manifold. (The O-rings should be up toward the manifold.) Check the Housing O-ring for proper position in its groove, engage and firmly tighten the Housing hand tight only.

### 3. Rinsing the system:

- Slowly open the Feed Water Saddle Valve fully counter clockwise.
- The Holding Tank Valve should be open.
- Check the Air Gap Window on the Dispensing Faucet to be sure that the drain water is flowing. (Refer to Figure 2, page 6.) The R.O. System is now making water.
- Do not open the Faucet for at least 8 hours.
- Do not use the first three full tanks of water.

**CAUTION:** The R.O. Membrane is shipped with a preservative in it. To ensure proper rinsing of the R.O. Membrane it is important to wait at least 8 hours before emptying each tank.

When the Faucet is first opened, expect air and carbon fines (very fine black powder) from the Activated Carbon Post Filter to be rinsed out. This is normal for the first tank of water or after the Activated Carbon Post Filter is changed.

## SECTION IV. OPERATION & MAINTENANCE

### A. Normal Operation

1. It is normal for the Total Dissolved Solids (TDS) of the water to be higher than normal during the first 5 gallons of operation; this is due to the sanitizing solution and the new Post Filter. After this water is rinsed to drain, the removal rate should stabilize at a value of greater than 75%.
2. R.O. systems produce drinking water at relatively slow rates; it can take up to 5 hours or more to fill the Holding Tank. Normal operation is to let the Holding Tank fill with water and then draw water as needed. When the pressure in the Holding Tank falls to a given pressure (as the water is being used) the Automatic Shutoff Valve (ASO Valve) will start water production and the system will refill the Holding Tank. When the Holding Tank is full and no water is being used, the ASO Valve will automatically shut-off the feed water to conserve water.

The more water that is used (up to the capacity of the system) the better the R.O. system will

function. Other uses for the water are flowers, pets and rinsing glassware.

With each use it is recommended that you turn the tap for at least 10 seconds prior to using water. This is especially important if the water tap has not been used daily. After periods of non-use, such as a week of vacation, it is better to empty the holding tank and allow the system to produce fresh water for use. If the system is not used for 3–4 weeks or longer, it is a good idea to resanitize the system and to change the Sediment/Carbon Prefilter and the Activated Carbon Post Filter.

### B. Changing Filters

THIS R.O. SYSTEM CONTAINS FILTERS WHICH MUST BE REPLACED AT REGULAR INTERVALS TO MAINTAIN PROPER PERFORMANCE. USE ONLY FACTORY APPROVED FILTERS.

**All individuals should take adequate precautions when changing the filters, including wearing protective gloves, to avoid direct contact with the exhausted filters.**

The recommended interval for changing the filters (not the R.O. Membrane) is every six (6) months. Typical T.F.C. Membrane life expectancy is three years. Local conditions may dictate more frequent changes.

**NOTE:** If the R.O. Membrane is to be replaced, see Sec. III, F.1–3, page 9 for the proper procedure.

Use a drip pan to catch any water that may spill when the Filter Housings are removed. Refer to Fig. 1, page 3 for component location.

1. Close the Feed Water Saddle Valve by turning fully clockwise and open the Dispensing Faucet by lifting the handle. Allow the Holding Tank to empty.
2. Loosen and remove the Sediment/Carbon Filter and the Activated Carbon Filter Housings. Discard the filters.
3. Wash the inside of the Housings using a mild detergent and a soft cloth. Do not use abrasive cleaners or pads. Thoroughly rinse all soap from the Housings before reassembly.
4. To sanitize the system and replace the filters:

**NOTE:** The system should be sanitized before installing the Sediment/Carbon Prefilter and Activated Carbon Post Filter.

- 
- Use a good quality unscented 5¼% liquid chlorine household bleach.
  - Add one capful of bleach (this is 2 tsp. or 10 ml) to the Sediment/Carbon Filter Housing and temporarily install the Housing without the Sediment/Carbon Prefilter.  
Check the Housing O–ring for proper position in its groove, engage and firmly tighten the Housing hand tight only.
  - Add one capful of bleach to the Activated Carbon Filter Housing. Carefully fill the Housing with tap water and temporarily install the Housing without the Activated Carbon Post Filter.
  - The Dispensing Faucet should be open, slowly open the Feed Water Saddle Valve.
  - As soon as water begins to drip out of the Dispensing Faucet, close the Faucet.
  - Let the system stand for 15 minutes.
  - At the end of 15 minutes, in the following order, close the Feed Water Saddle Valve, close the Holding Tank Valve and open the Dispensing Faucet to release the pressure.
  - Remove the Sediment/Carbon Filter Housing and empty. Remove the wrapping and install the Sediment/Carbon Prefilter. Firmly tighten the Housing hand tight only.
  - Remove the Activated Carbon Filter Housing and empty. Remove the wrapping and install the Activated Carbon Post Filter. Firmly tighten the Housing hand tight only.
  - Disconnect the yellow product water tubing that runs from the Holding Tank to the Manifold (see Fig. 1, page 3). Put 50 drops of bleach (this is ½ tsp. or 3 ml) into the tubing and reconnect it.
  - Slowly open the Feed Water Saddle Valve. When water begins dripping out of the Dispensing Faucet, in the following order, close the Faucet and then open the Holding Tank Valve.
  - Do not open the Faucet for at least 8 hours.
  - Discard the first three full tanks of water produced; they will contain chlorine.
  - When the Faucet is first opened, expect air and carbon fines (very fine black powder), from the new Activated Carbon Post Filter to be rinsed out. This is normal for the first tank of water.

**SECTION V. TROUBLE SHOOTING GUIDE**

<b>Problem</b>	<b>Possible Cause</b>	<b>Solution</b>
<b>Low quantity of Product Water from Holding Tank</b>	Feed Water Saddle Valve is plugged or closed.	Open Valve or unclog.
	Clogged Sediment/Carbon Prefilter or Activated Carbon Post Filter.	Replace filters.
	Low water pressure	Feed Water pressure must be above 40 psig.
	R.O. Membrane is fouled.	See Feed Water operating limits. Correct cause of fouling, replace Membrane.
	Air precharge pressure in Holding Tank is too high.	Empty water from Holding Tank, and with the faucet open, adjust air pressure to 5–7 psig (35–48 kPa) range.
	Air precharge is too low.	
	Air bladder in the Holding Tank is ruptured.	Replace tank.
	Holding Tank Valve is closed.	Open Valve.
	No drain flow, the Drain Restrictor is plugged.	Clear or replace Drain Restrictor.
	No drain flow, the drain orifice in the Air Gap Faucet is plugged.	Clear or replace the Air Gap Faucet.
	The Check Valve is stuck.	Free check.
	The ASO Valve is malfunctioning.	Replace ASO Valve components.
<b>Low pressure at the Dispensing Faucet</b>	Activated Carbon Post Filter is plugged.	Replace Post Filter.
	Air precharge in the Holding Tank is too low.	Empty water from Holding Tank and with the faucet open, adjust the air pressure to 5–7 psig (35–48 kPa) range. Check for leakage at the Air Valve Stem.
	Holding Tank Valve is partially closed.	Open Valve.
	The dispensing Faucet is out of adjustment or faulty.	Repair or replace Dispensing Faucet.
	Heavy water use, Holding Tank is depleted.	Allow Holding Tank to refill (adding a second Holding Tank will increase storage capacity).
	Low Water Production.	See Low Quantity of Product Water from Holding Tank section above.
	<b>High Total Dissolved Solids (TDS) in the Product Water</b>	Clogged Sediment/Carbon Prefilter.
Low Water Pressure.		Feed Water Pressure must be above 40 psig.
		Check Feed Water Saddle Valve.
R.O. Membrane O–ring is crimped.		Check O–ring.
R.O. Membrane brine seal is not sealing up into the manifold head.		Check the brine seal.
R.O. Membrane is expended.		If Membrane life is unusually short, find and correct the problem. Replace Membrane.

<b>Problem</b>	<b>Possible Cause</b>	<b>Solution</b>
<b>High Total Dissolved Solids (TDS) in the Product Water (continued)</b>	The Product Water and Drain Water lines are reversed.	Correct plumbing.
	No drain flow, Drain Restrictor is clogged.	Clear or replace Drain Restrictor.
	No drain flow, the drain orifice in the Air Gap Faucet is plugged.	Clear or replace Air Gap Faucet.
	The ASO Valve is not closing.	Repair or replace the ASO Valve Components.
	New Activated Carbon Post Filter not rinsed completely.	Flush with several full tanks of Product Water.
	The Feed Water TDS has increased.	An increase in Feed Water TDS will give a corresponding increase in Product Water TDS.
<b>Tastes and odors in the Product Water</b>	The Activated Carbon Post Filter is exhausted.	Replace Filter.
	There is foreign matter in the Holding Tank.	Clean, flush and sanitize the system. Replace the filters.
	The Product Water and Drain Water lines are reversed.	Correct plumbing.
	Dissolved gasses in the Feed Water.	Pretreat Feed Water to remove dissolved gasses.
	Increase in Product Water TDS.	See high TDS in the Product Water section.
<b>Drain Water overflows at the Air Gap Faucet</b>	Air Gap is blocked.	Clear Air Gap.
		Rinse with vinegar for removal of calcium buildup.
	Drain tubing is clogged.	Clear tubing.
	Drain Clamp hole is misaligned.	Align with hole in the drain pipe.
	Excessive drain flow rate.	Replace Drain Restrictor.
<b>Faucet leaks or drips</b>	Leaks from spout.	Adjust Faucet by turning the tee bar just below the handle to provide a small amount of free play in handle when shut off.
		O-rings are bad, repair or replace faucet.
	Leaks from base of the delivery tube.	O-ring is bad, replace O-ring.
	Leaks from beneath the handle.	O-rings are bad. Repair or replace the faucet.
<b>Fitting leaks in general</b>	Close the Feed Water Saddle Valve and relieve pressure before disconnecting any tubing or replacing any fitting. Before replacing a fitting, re-cut the tubing and re-insert into the fitting to see if that solves the leak. If pipe threads are leaking, remove and retape with Teflon tape.	

# EXPLODED VIEW & PARTS LIST

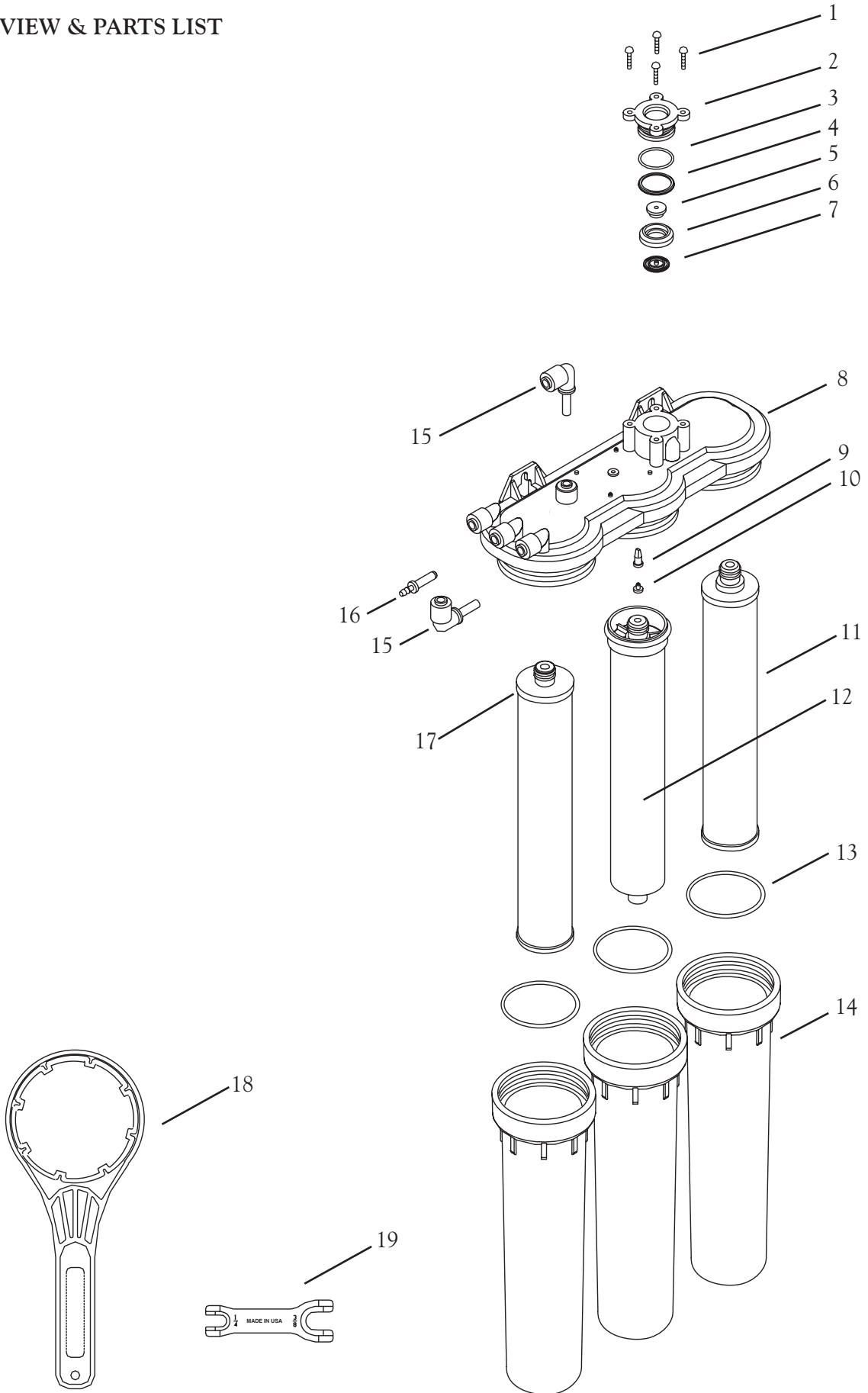

<b>DRAWING NO.</b>	<b>PART NO.</b>	<b>DESCRIPTION</b>
1.....	S2009 .....	Self Tapping Screw
2.....	S2005PP.....	ASO Cap
3.....	S2013 .....	ASO Cap O-Ring
4.....	S2011 .....	ASO Diaphragm – Large
5.....	S2007PP.....	ASO Piston
6.....	S2006PP.....	ASO Piston Ring
7.....	S2010 .....	ASO Diaphragm – Small
8.....	NSSTF0405M38PP .....	Manifold Plate Assembly (Includes diagram numbers 1 through 10, 15, 16)
9.....	S1276 .....	Check Valve
10.....	S1277 .....	Check Valve Retainer
11.....	S7028 .....	Sediment/Carbon Prefilter
12.....	S1764RS .....	T.F.C. R.O. Membrane 50 gpd (189 lpd)
13.....	S3069 .....	Housing O-Ring
14.....	S7029-09 .....	Housing
15.....	PK-A6TEU4-MG.....	1/4" Post X 3/8" Polytube Elbow
16.....	S2116-5 .....	Drain Restrictor 50 GPD (189 lpd) Green
17.....	S7025 .....	Activated Carbon Post Filter
18.....	S3072 .....	Wrench for Housing
19.....	S1405 .....	1/4"-3/8" Fitting Wrench

**OTHER COMPONENTS AS SHOWN IN FIGURE 1, PAGE 3.**

<b>DRAWING NO.</b>	<b>PART NO.</b>	<b>DESCRIPTION</b>
1.....	S1089-20 .....	Long Reach Air Gap Faucet
2.....	S1117-01 .....	3/8" Drain Clamp Assembly
4.....	S1118-01 .....	Feed Water Saddle Valve
5.....	C2000F .....	Holding Tank
6.....	S1037 .....	Holding Tank Shut-Off Valve

  
**R.O. DRINKING WATER SYSTEM  
FIVE/ONE YEAR LIMITED WARRANTY**

**What Does This Warranty Cover?**

*This warranty covers any defects in materials and workmanship of the R.O. Drinking Water System when installed and operated within recommended parameters, with the exceptions stated below.*

**How Long Does The Coverage Last?**

*The manufacturer will warrant its R.O. Drinking Water System (except for the reverse osmosis membrane), for a period of five years from the date of purchase. The reverse osmosis membrane is warranted for one year from date of purchase. All implied warranties including merchantability and fitness for a particular purpose are limited to five years from the date of purchase for the R.O. Drinking Water System, except for the reverse osmosis membrane which is limited to one year from date of purchase. Some states do not allow limitations on how long an implied warranty lasts, so the above limitations may not apply to you.*

**What Will The Manufacturer Do?**

*The manufacturer will repair or replace at its discretion any defective component. You must pay any labor charges. You must also pay for shipping or travel charges to return the defective part(s).*

**What Does This Warranty Not Cover?**

*This warranty does not cover the disposable sediment and carbon filters whose service life depends on feed water conditions. In addition, the membrane is only warranted if the required feed water conditions are met.*

*The above warranty will also not apply to any part of the R.O. Drinking Water System that is damaged because of neglect, misuse, alterations, accident, misapplication, physical damage, or damage caused by fire, acts of God, freezing or hot waters or similar causes. Consequential and incidental damages are not recoverable under this warranty. Some states do not allow the exclusion or limitation of incidental or consequential damages, so the above limitation or exclusion may not apply to you.*

*We recommend that you use only the manufacturer's replacement parts since improper parts or incorrectly performed maintenance or repair voids this warranty.*

**How Do You Get Service?**

*In order to be eligible for service under this warranty you must (a) contact your local dealer who supplied the unit.*

**How Does State Law Apply?**

*This warranty gives you specific legal rights and you may also have other rights which vary from state to state.*

**Your Water Treatment Professional:**